

NI 5772R

Digitizer Adapter Module

The NI 5772 is a high-speed digitizer adapter module designed to work in conjunction with your NI FlexRIO™ FPGA module. The NI 5772 features two analog input (AI) channels with 12-bit resolution and sample rates up to 800 MS/s when using both channels or sample rates up to 1.6 GS/s when using only one channel. The NI 5772R is available in two versions: an AC-coupled version and a DC-coupled version.

This document contains signal information and lists the specifications of the NI 5772R, which is composed of the NI FlexRIO FPGA module and the NI 5772. This document also contains tutorial sections that demonstrate how to acquire data using a LabVIEW FPGA Example VI and how to create and run your own LabVIEW project with the NI 5772R.



Note NI 5772R refers to the combination of your NI 5772 adapter module and your NI FlexRIO FPGA module. NI 5772 refers to your NI 5772 adapter module only.



Note Before configuring your NI 5772R, you must install the appropriate software and hardware. Refer to the *NI FlexRIO FPGA Module Installation Guide and Specifications* for installation instructions.

The following figure shows an example of a properly connected NI FlexRIO device.

Figure 1. NI FlexRIO Device

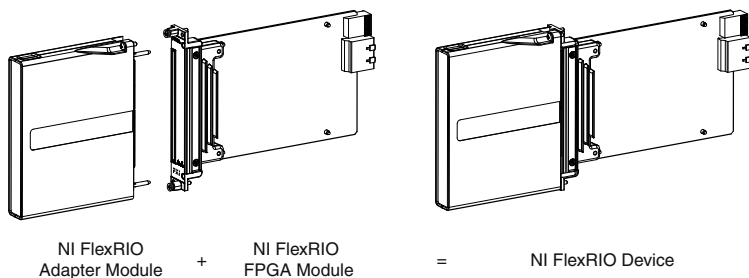

Contents

Electromagnetic Compatibility Guidelines.....	2
Connecting Cables.....	3

How to Use Your NI FlexRIO Documentation Set.....	3
Front Panel and Connector Pinouts.....	5
AUX I/O Connector.....	7
Block Diagrams.....	8
NI 5772 Component-Level Intellectual Property (CLIP).....	9
NI 5772 CLIP.....	10
Using Your NI 5772R with a LabVIEW FPGA Example VI.....	12
FPGA Example VI Steps.....	12
Creating a LabVIEW Project and Running a VI on an FPGA Target.....	13
Clocking.....	16
NI 5772 Specifications.....	18
Analog Input (AI 0 and AI 1).....	19
Analog Input Impedance.....	21
Internal Sample Clock.....	27
CLK IN.....	28
REF IN.....	28
TRIG (I/O).....	28
AUX I/O (Port 0 DIO <0..3>, Port 1 DIO <0..3>, and PFI <0..3>).....	29
EEPROM Map.....	29
Power.....	30
Physical.....	30
Environment.....	30
Compliance and Certifications.....	31
Worldwide Support and Services.....	33
Installing PXI EMC Filler Panels.....	33

Electromagnetic Compatibility Guidelines

This product was tested and complies with the regulatory requirements and limits for electromagnetic compatibility (EMC) stated in the product specifications. These requirements and limits are designed to provide reasonable protection against harmful interference when the product is operated in the intended operational electromagnetic environment.

This product is intended for use in industrial locations. However, harmful interference may occur in some installations, when the product is connected to a peripheral device or test object, or if the product is used in residential or commercial areas. To minimize interference with radio and television reception and prevent unacceptable performance degradation, install and use this product in strict accordance with the instructions in the product documentation.

Furthermore, any modifications to the product not expressly approved by National Instruments could void your authority to operate it under your local regulatory rules.



Caution To ensure the specified EMC performance, you must install PXI EMC Filler Panels (National Instruments part number 778700-01) in adjacent chassis slots. Installing PXI EMC Filler Panels in all empty slots is recommended. You can

order a kit of six single slot EMC Filler Panels directly from NI by visiting ni.com/info and entering partnumber.



Caution To ensure the specified EMC performance, operate this product only with shielded cables and accessories.



Caution To ensure the specified EMC performance, the length of all I/O cables must be no longer than 3 m (10 ft).

Related Information

[Installing PXI EMC Filler Panels](#) on page 33

Connecting Cables

1. Use any shielded 50 Ω SMA cable to connect signals to the connectors on the front panel of your device.
2. Use the SHH19-H19-AUX cable (NI part number: 152629-01 or 152629-02) to connect to the digital I/O (DIO) and programmable function interface (PFI) signals on the AUX I/O connector. NI recommends using the SCB-19 connector block to access the DIO and PFI signals.

How to Use Your NI FlexRIO Documentation Set

Refer to Figure 2 and Table 1 to learn how to use your FlexRIO documentation set.

Figure 2. How to Use Your NI FlexRIO Documentation Set.

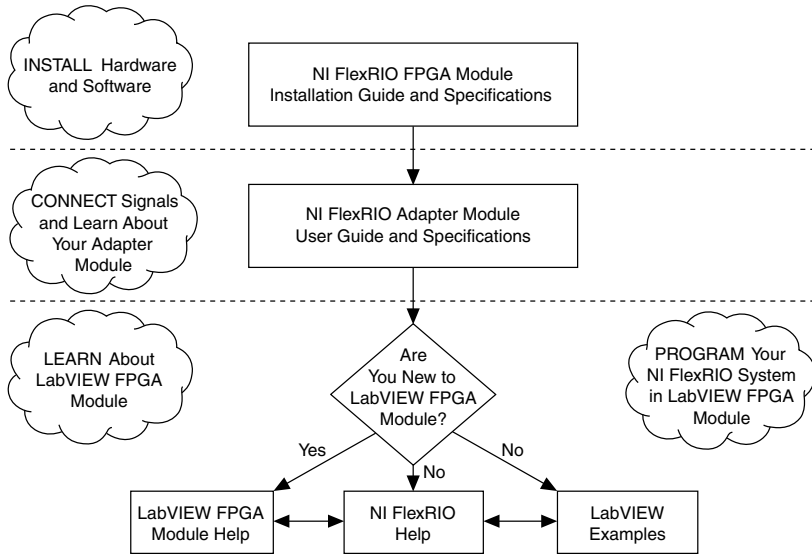

Table 1. NI FlexRIO Documentation Locations and Descriptions

Document	Location	Description
<i>NI FlexRIO FPGA Module Installation Guide and Specifications</i>	Available from the Start menu and at ni.com/manuals .	Contains installation instructions for your NI FlexRIO system and specifications for your FPGA module.
<i>NI 5772R User Manual and Specifications</i> (this document)	Available from the Start menu and at ni.com/manuals .	Contains signal information, examples, CLIP details, and specifications for your adapter module.
<i>LabVIEW FPGA Module Help</i>	Embedded in <i>LabVIEW Help</i> and at ni.com/manuals .	Contains information about the basic functionality of the LabVIEW FPGA Module.
<i>NI FlexRIO Help</i>	Available from the Start menu and at ni.com/manuals .	Contains FPGA Module, adapter module, and CLIP configuration information.
LabVIEW Examples	Available in NI Example Finder.	Contains examples of how to run FPGA VIs and Host VIs on your device.

Table 1. NI FlexRIO Documentation Locations and Descriptions (Continued)

Document	Location	Description
IPNet	ni.com/ipnet	Contains LabVIEW FPGA functions and intellectual property to share.
NI FlexRIO product page	ni.com/flexrio	Contains product information and data sheets for NI FlexRIO devices.

Front Panel and Connector Pinouts

Table 2 shows the front panel connector and signal descriptions for the NI 5772.



Caution To avoid permanent damage to the NI 5772, disconnect all signals connected to the NI 5772 before powering down the module, and connect signals only after the adapter module has been powered on by the NI FlexRIO FPGA module.

Table 2. NI 5772 Front Panel Connectors

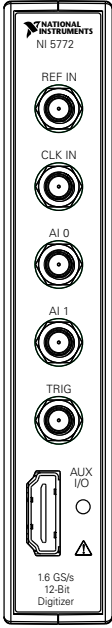
Device Front Panel	Connector	Signal Description
	REF IN	External Reference Clock input, 50 Ω, single-ended.
	CLK IN	External Sample Clock input, 50 Ω, single-ended.
	AI 0	Analog input channel 0, 50 Ω, single-ended.
	AI 1	Analog input channel 1, 50 Ω, single-ended.
	TRIG	Trigger input and output channel.
	AUX I/O	Refer to Table 3 for the signal list and descriptions.



Caution Connections that exceed any of the maximum ratings of any connector on the NI 5772R can damage the device and the chassis. NI is not liable for any damage resulting from such connections.

Related Information

[NI 5772 Specifications](#) on page 18

AUX I/O Connector

Table 3. NI 5772 AUX I/O Connector Pin Assignments

AUX I/O Connector	Pin	Signal	Signal Description
	1	DIO Port 0 (0)	Bidirectional single-ended (SE) digital I/O (DIO) data channel.
	2	GND	Ground reference for signals.
	3	DIO Port 0 (1)	Bidirectional SE DIO data channel.
	4	DIO Port 0 (2)	Bidirectional SE DIO data channel.
	5	GND	Ground reference for signals.
	6	DIO Port 0 (3)	Bidirectional SE DIO data channel.
	7	DIO Port 1 (0)	Bidirectional SE DIO data channel.
	8	GND	Ground reference for signals.
	9	DIO Port 1 (1)	Bidirectional SE DIO data channel.
	10	DIO Port 1 (2)	Bidirectional SE DIO data channel.
	11	GND	Ground reference for signals.
	12	DIO Port 1 (3)	Bidirectional SE DIO data channel.
	13	PFI 0	Bidirectional SE DIO data channel.
	14	NC	No connect.
	15	PFI 1	Bidirectional SE DIO data channel.
	16	PFI 2	Bidirectional SE DIO data channel.
	17	GND	Ground reference for signals.
	18	+5 V	+5 V power (10 mA maximum).
	19	PFI 3	Bidirectional SE DIO data channel.



Caution The AUX I/O connector accepts a standard, third-party HDMI cable, but the AUX I/O port is not an HDMI interface. Do not connect the AUX I/O port on the NI 5772 to the HDMI port of another device. NI is not liable for any damage resulting from such signal connections.

Block Diagrams

The following figure shows the NI 5772 block diagram and signal flow.

Figure 3. NI 5772 Connector Signals and NI 5772 CLIP Signal Block Diagram

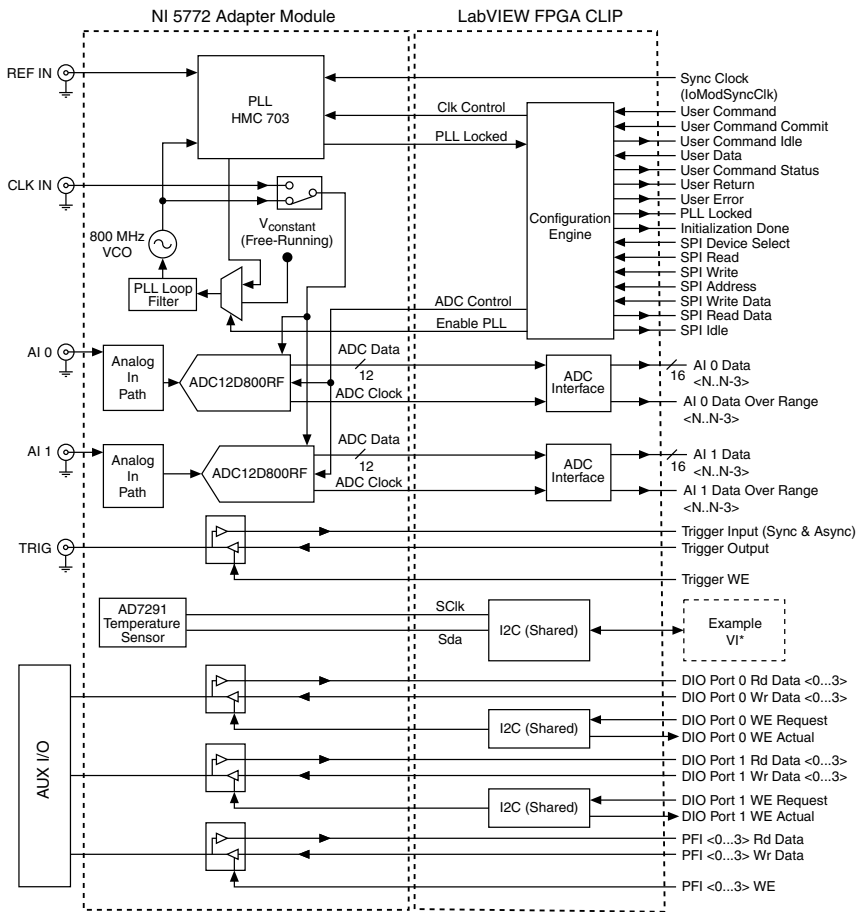

Related Information

[Using Your NI 5772R with a LabVIEW FPGA Example VI](#) on page 12

NI 5772 Component-Level Intellectual Property (CLIP)

The LabVIEW FPGA Module includes component-level intellectual property (CLIP) for HDL IP integration. NI FlexRIO devices support two types of CLIP: user-defined and socketed.

- *User-defined CLIP* allows you to insert HDL IP into an FPGA target, enabling VHDL code to communicate directly with an FPGA VI.
- *Socketed CLIP* provides the same IP integration of the user-defined CLIP, but also allows the CLIP to communicate directly with circuitry external to the FPGA. Adapter module socketed CLIP allows your IP to communicate directly with both the FPGA VI and the external adapter module connector interface.

The following figure shows the relationship between an FPGA VI and the CLIP.

Figure 4. CLIP and FPGA VI Relationship

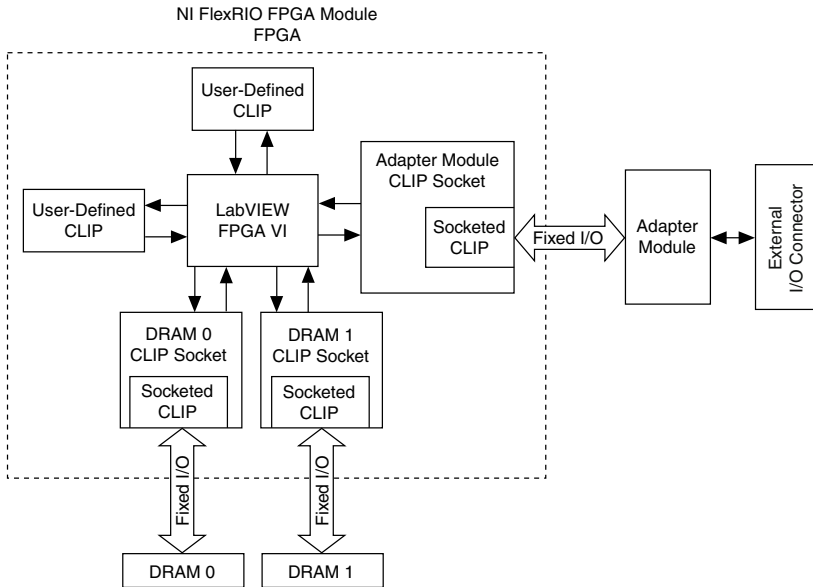

The NI 5772 ships with socketed CLIP items that add module I/O to the LabVIEW project.

NI 5772 CLIP

The NI 5772 ships with the following CLIP items:

- **NI 5772 CLIP**—This CLIP provides access to two analog input channels, eight bidirectional DIO channels, four bidirectional PFI channels, and an input clock selector that can be configured to use one of the following settings:
 - Internal Sample Clock
 - Internal Sample Clock locked to an external Reference Clock through the REF IN connector
 - External Sample Clock through the CLK IN connector
 - Internal Sample Clock locked to an external Reference Clock through IoModSyncClock

The CLIP also contains an engine to program the ADC and Sample Clock circuit, either through predetermined settings for an easier instrument setup, or through a raw SPI address and data signals for a more advanced setup. In the LabVIEW FPGA Module, 12-bit analog input data is accessed using an I16 data type (left-justified). The DIO signals are grouped into two ports of four signals each and are accessed using a U8 data type and a Boolean write enable signal. The four PFI signals are accessed individually using Boolean indicators.

Although real-time sampling is the default sampling mode on the NI 5772, the NI 5772 CLIP also supports Time-Interleaved Sampling (TIS) on one analog input channel at a time. TIS enables the device to use both channels on the ADC to sample the same input channel at different relative phases, which doubles the real-time sampling rate. The NI 5772 then interleaves the samples to create a waveform as if only one ADC channel was sampling the waveform at twice the Sample Clock rate. The data is returned on the AI 0 Data <N..N-3> and AI 1 Data <N..N-3> signals even though the device is only sampling the single analog input channel that you selected. To configure the NI 5772 for TIS mode using this CLIP, refer to the *NI FlexRIO Adapter Module Support* book in the *NI FlexRIO Help*.

The following figure demonstrates TIS on an NI 5772 device.

Figure 5. TIS Mode

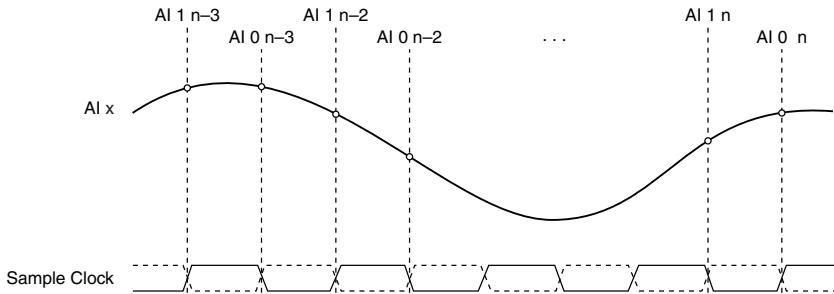

Note The ADC data sheet refers to TIS as *Dual-Edge Sampling (DES)*.

- **NI 5772 Synchronized Reference Clock CLIP**—This CLIP is the National Instruments NI 5772 Terminal Block, and it provides FlexRIO Instrument Development Library (FIDL) synchronization using an external 10 MHz reference. This CLIP also provides access to two analog input channels, eight bidirectional DIO channels, four bidirectional PFI channels, and an input clock selector that can be configured to use one of the following settings:
 - Internal Sample Clock
 - Internal Sample Clock locked to an external Reference Clock through the REF IN connector
 - Internal Sample Clock locked to an external Reference Clock through IoModSyncClock

This CLIP also enables the user to synchronize two or more modules using an external reference.

- **NI 5772 Synchronous External Clock CLIP**—This CLIP provides access to the same features as the NI 5772 CLIP, described above, except it only allows sampling from an external Sample Clock, and it enables synchronization of two or more modules using an external Sample Clock.

Refer to the *NI FlexRIO Adapter Module Support* book within the *NI FlexRIO Help* for more information about NI FlexRIO CLIP items, how to configure the NI 5772 with a socketed CLIP, and for a list of available socketed CLIP signals.

Using Your NI 5772R with a LabVIEW FPGA Example VI



Note You must install the software before running this example. Refer to the *NI FlexRIO FPGA Installation Guide and Specifications* for more information about installing your software.

The NI FlexRIO Adapter Module Support software includes an example project to help you get started creating your LabVIEW FPGA application. This section explains how to use an existing LabVIEW FPGA example project to generate and acquire samples with the NI 5772R. This example requires at least one SMA cable for connecting signals to your NI 5772R.



Note The examples available for your device are dependent on the version of the software and driver you are using. For more information about which software versions are compatible with your device, visit ni.com/info, enter `rdsoftwareversion` in the text field, and click the NI FlexRIO link in the results.

The NI 5772R example project includes the following components:

- A LabVIEW FPGA VI that you can compile and run on the FPGA embedded in the hardware
- At least one VI that runs on Windows and interacts with the LabVIEW FPGA VI



Note In the LabVIEW FPGA Module software, NI FlexRIO adapter modules are referred to as *IO Modules*.

Related Information

[Block Diagrams](#) on page 8

FPGA Example VI Steps

1. Connect one end of an SMA cable to AI 0 on the NI 5772 front panel and the other end of the cable to your device under test (DUT).
2. Launch LabVIEW.
3. Click **Help»Find Examples** to launch the NI Example Finder.
4. In the **NI Example Finder** window, select **Hardware Input and Output»FlexRIO»IO Modules»NI 5772**.
5. Select **NI 5772 - Getting Started.lvproj**.
6. In the **Project Explorer** window, open **NI 5772 - Getting Started (Host).vi** under **My Computer** to open the host VI. The Open FPGA VI Reference function in this VI uses the NI PXI-7952R as the FPGA target by default. If you are using an NI FlexRIO FPGA module other than the NI PXI-7952R, complete the following steps to change to the FPGA VI to support your target.
 - a) Select **Window»Show Block Diagram** to open the VI block diagram.
 - b) On the block diagram, right-click the Open FPGA VI Reference (PXI-7952R) function and select **Configure Open FPGA VI Reference**.

- c) In the **Configure Open FPGA VI Reference** dialog box, click the **Browse** button next to the **Bitfile** button.
 - d) In the **Select Bitfile** dialog box that opens, select the bitfile for your desired target. The bitfile name is based on the adapter module, example type, and FPGA module.
 - e) Click the **Select** button.
 - f) Click **OK** in the **Configure Open FPGA VI Reference** dialog box.
 - g) Save the VI.
7. On the front panel, in the **RIO Resource** pull-down menu, select an NI 5772R resource that corresponds with the target configured in step 6.
 8. Select **AI 0** in the **AI Channel** control.
 9. Set the **Trigger Level (V)** and the **Record Size** controls to the desired value.
 10. In the **Trigger Type** box, you can select either **Software** or **Data Edge**. If you select **Software**, the VI acquires data every time you click the **Software Trigger** front panel button. If you select **Data Edge**, the VI acquires data every time an edge occurs.
 11. Click the **Run** button to run the VI.
 12. Click the **Software Trigger** button if you selected **Software** in the **Trigger Type** control. The VI acquires data and displays the captured waveform on the **Acquired Waveform** graph as shown in the figure below.
 13. Click the **STOP** button to stop the VI.
 14. Close the VI.

Figure 6. NI 5772 - Getting Started (Host) VI Front Panel

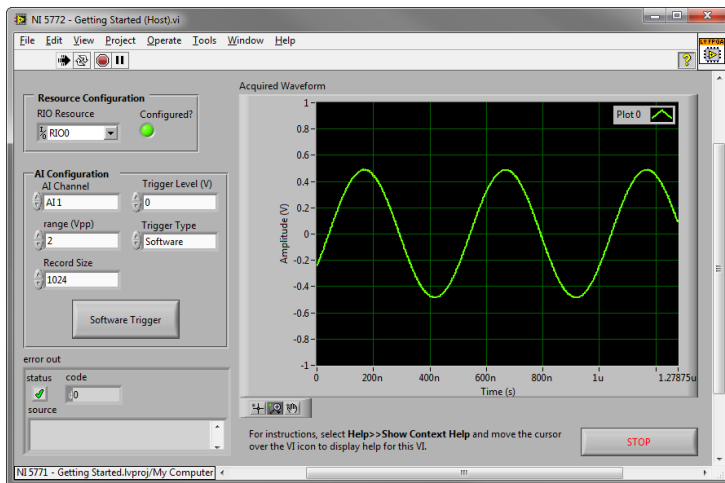

Creating a LabVIEW Project and Running a VI on an FPGA Target

This section explains how to set up your target and create an FPGA VI and host VI for data communication. This section focuses on proper project configuration, proper CLIP

configuration, and how to access NI 5772 I/O nodes. For more detailed information about acquiring data on your NI 5772R, refer to the streaming example available in NI Example Finder.

Creating a Project

1. Launch LabVIEW, or if LabVIEW is already running, select **File»Create Project**.
2. In the **Create Project** dialog box, select **FPGA Template** and click **OK**. The new project opens in the **Project Explorer** window.
3. Save the project as `5772SampleAcq.lvproj`.

Creating an FPGA Target VI

1. In the **Project Explorer** window, right-click **My Computer** and select **New»Targets and Devices**.
2. In the **Add Targets and Devices on My Computer** dialog box, select the **Existing Target or Device** option button and expand **FPGA Target** to display the target.
3. Select your device and click **OK** to load the target and target properties into the **Project Explorer** window.
4. In the **Project Explorer** window, expand **FPGA Target (RIOx, PXI-79xxR)**.
5. Right-click **FPGA Target (RIOx, PXI-79xxR)** and select **New»FPGA Base Clock**.
6. In the **Resource** pull-down menu, select **IO Module Clock 0** and click **OK**.
7. Right-click **IO Module** in the **Project Explorer** window and select **Properties**.
8. Select the NI 5772 from the **IO Module** list. The available CLIP for the NI 5772 is displayed in the **General** category of the **Component Level IP** pane. If the information in the **General** category is dimmed, select the **Enable IO Module** checkbox.
9. Select in the **Name** list of the **Component Level IP** pane.
10. In the **Clock Selections** category, select **200 MHz Clock** from the pull-down menu for **Clk200**. Leave **Clk40** configured as the **Top-Level Clock**.
11. Click **OK**.



Note Configuring these clocks is required for proper CLIP operation. Refer to the NI 5772 CLIP topics in the *NI FlexRIO Help* for more information about configuring your clocks.

12. In the **Project Explorer** window, right-click the FPGA target and select **New»VI**. A blank VI opens.
13. Select **Windows»Show Block Diagram** to open the VI block diagram.
14. In the **Project Explorer** window, expand the **IO Module (NI 5771: NI 5771)** tree view.
15. Drag **AI 0 Data N-3** to the block diagram.
16. Click the handle on the bottom of the control node with the Positioning tool and drag the edge down to expose the other signals, **AI 0 Data N-2...AI 0 Data N** control node.
17. Add a Timed Loop structure around the node.
18. Wire indicators to the output terminals of the **IO Module\AI 0 Data N-3...AI 0 Data N**.
19. Right-click the input node of the Timed Loop to wire an FPGA Clock Constant. Set this constant to **Divided Sample Clock**.

Figure 7. NI 5772SampleAcq (FPGA).vi Block Diagram

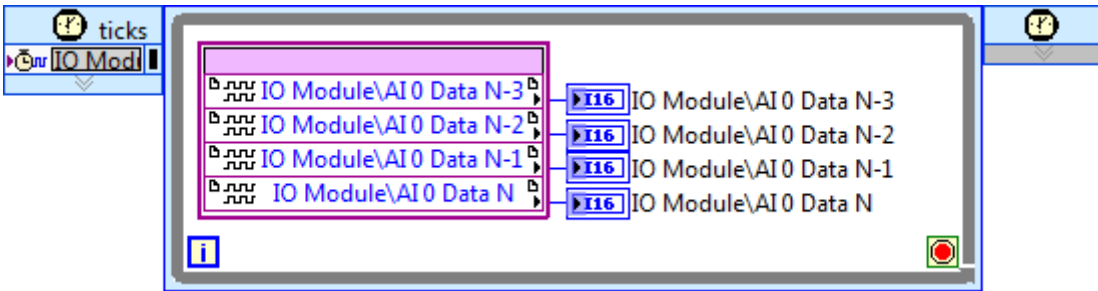

20. Save the VI as `5772SampleAcq(Host).vi`.
21. Click the **Run** button. LabVIEW creates a default build specification and begins compiling the VI. The **Generating Intermediate Files** window opens and displays the code generation progress. Next, the **Compilation Status** window opens and displays the progress of the compilation. The compilation takes several minutes.
22. Click **Close** in the **Compilation Status** window.
23. Save and close the VI.
24. Save the project.

Creating a Host VI

1. In the **Project Explorer** window, right-click **My Computer** and select **New»VI** to open a blank VI.
2. Select **Window»Show Block Diagram** to open the VI block diagram.
3. Place the Open FPGA VI Reference function, located on the **FPGA Interface** palette, on the block diagram.
4. Right-click the Open FPGA VI Reference function, and select **Configure Open FPGA VI Reference**.
5. In the **Configure Open FPGA VI Reference** dialog box, select **VI** in the **Open** section.
6. In the **Select VI** dialog box that opens, select **5772SampleAcq (FPGA).vi** under your device and click **OK**.
7. Click **OK** in the **Configure Open FPGA VI Reference** dialog box. The target name appears under the Open FPGA VI Reference function in the block diagram.
8. Add a While Loop to the block diagram. Place the While Loop to the right of the Open FPGA VI Reference function.
9. Right-click the conditional terminal inside the While Loop, and select **Create Control** to create a STOP button on the VI front panel window.
10. Add the Read/Write Control function, located on the **FPGA Interface** palette, inside the While Loop.
11. Wire the **FPGA VI Reference Out** output of the Open FPGA VI Reference function to the **FPGA VI Reference In** input on the **Read/Write Control** function.
12. Wire the **error out** output of the Open FPGA VI Reference function to the **error in** input of the **Read/Write Control** function.

13. Configure the Read/Write Control function by clicking the terminal section labeled **Unselected**, and selecting **IO Module/AI 0 Data N-3**.
14. Click the handle on the bottom of the control node with the Positioning tool and drag the edge down to add the other signals, **AI 0 Data N-2...AI 0 Data N**, to the Read/Write Control function.
15. Wire indicators to the output terminals of the **IO Module\AI 0 Data N-3...AI 0 Data N** control node.
16. Add the Close FPGA VI Reference function, located on the **FPGA Interface** palette, to the right of the While Loop.
17. Wire the **FPGA VI Reference Out** output of the Read/Write Control function to the **FPGA VI Reference In** input of the Close FPGA VI Reference function.
18. Wire the **error out** output of the Read/Write Control function to the **error in** input of the Close FPGA VI Reference function.

Your block diagram should now resemble the block diagram in the figure below.

Figure 8. 5772SampleAcq (Host).vi Block Diagram

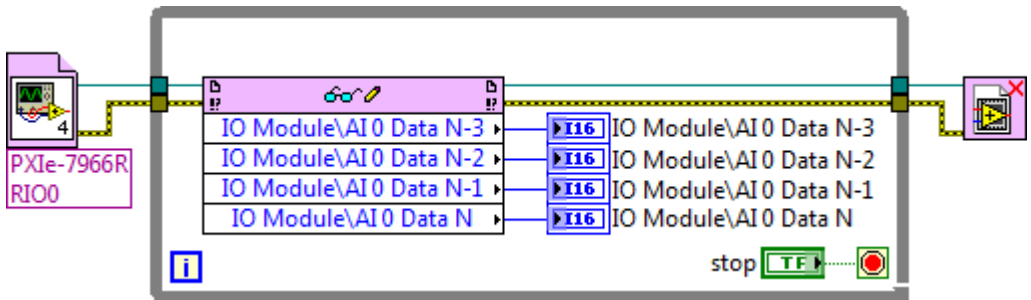

19. Save the VI as `5772SampleAcq (Host) .vi`.

Run the Host VI

1. Connect one end of an SMA cable to AI 0 on the front panel of the NI 5772 and the other end of the cable to your DUT.
2. Open the front panel of `5772SampleAcq (Host) .vi`.
3. Click the **Run** button to run the VI.
4. The VI acquires data from the DUT on **AI 0 Data N** and **AI 0 Data N-1**.
5. Click the **STOP** button on the front panel and close the VI.

Clocking

The NI 5772 clock source controls the sample rate and other timing functions on the device. The following table contains information about the possible NI 5772 clock sources.

Table 4. NI 5772 Clock Sources

Clock Source	Frequency¹	Description
Internal Free-Running Sample Clock	800 MHz	The internal Sample Clock is free-running.
Internal Sample Clock PLL On (IoModSyncClock)	800 MHz	The internal Sample Clock locks to IoModSyncClock, which is provided only through the backplane of NI PXIe-796x devices.
Internal Sample Clock PLL On (REF IN)	800 MHz	The internal Sample Clock locks to an external 10 MHz Reference clock, which is provided through the REF IN front panel connector.
External Sample Clock (CLK IN)	400 MHz to 800 MHz	An external Sample Clock can be provided through the CLK IN front panel connector.



Note Do *not* connect an external Sample Clock with a frequency greater than 800 MHz to the CLK IN front panel connector to acquire data at rates greater than 800 MS/s. Instead, use an external clock with a frequency between 400 MHz and 800 MHz and configure the CLIP to use TIS.

You can configure the NI 5772 to use a variety of sampling modes. By default, the NI 5772 takes samples at 800 MS/s through both analog input channels; however, you can take samples through one analog input channel to increase the sample rate. The table below lists the sampling modes available on the NI 5772.

¹ You can use TIS to acquire up to 1.6 GS/s. Refer to the *NI FlexRIO Help* for more information about configuring your NI 5772 CLIP.

Table 5. Sampling Modes

Mode	Sample Rate (MS/s)	Full-Scale Input Power Range (dBm)	Number of Channels	Connection Description
TIS Disabled (default)	400 to 800	10	2	Use both CH 0 and CH 1. The device samples both channels simultaneously.
TIS Enabled, Multiplexed to CH 0	800 to 1,600	10	1	Use <i>only</i> CH 0. Disconnect or terminate unused channels.
TIS Enabled, Multiplexed to CH 1	800 to 1,600	10	1	Use <i>only</i> CH 1. Disconnect or terminate unused channels.
TIS Enabled, Non-Multiplexed ²	800 to 1,600	16	1	Use CH 0 <i>or</i> CH 1. You can only use one channel. You <i>must</i> terminate the unused channel with the 50 Ω terminator.

NI 5772 Specifications

Specifications are warranted by design and under the following conditions unless otherwise noted:

- Chassis fan speed is set to High. In addition, NI recommends using slot blockers and EMC filler panels in empty module slots to minimize temperature drift.
- The NI 5772 uses NI LabVIEW and LabVIEW FPGA software.

Specifications describe the warranted product performance over ambient temperature ranges of 0 °C to 55 °C, unless otherwise noted.

Typical values describe useful product performance beyond specifications that are not covered by warranty and do not include guardbands for measurement uncertainty or drift. Typical values may not be verified on all units shipped from the factory. Unless otherwise noted, typical values cover the expected performance of units over ambient temperature ranges of 23 °C \pm 5 °C with a 90% confidence level, based on measurements taken during development or production.

² This sampling mode is available in the AC-coupled version only.

Nominal values (or supplemental information) describe additional information about the product that may be useful, including expected performance that is not covered under Specifications or Typical values. Nominal values are not covered by warranty.

Related Information

[Front Panel and Connector Pinouts](#) on page 5

Analog Input (AI 0 and AI 1)

General Characteristics

Number of channels.....	Two
Connector type.....	SMA
Input type.....	Single-ended, simultaneously sampled or time-interleaved sampled (TIS)
Input impedance ³	50 Ω , per connector
Input coupling.....	AC (-01L version); DC (-02L version)
Digital data resolution.....	12-bit, signed, binary data ⁴
ADC part number.....	ADC12D800RF ⁵
Absolute maximum voltage.....	± 10 VDC, +21 dBm (7.1 V _{pk-pk})

Typical Specifications

All specifications were tested in TIS Disabled mode unless otherwise specified.

DC offset

AC-coupled.....	± 4.3 mV
DC-coupled.....	± 6.5 mV

Full-scale input..... +10 dBm (2 V_{pk-pk}) or +16 dBm (4 V_{pk-pk})⁶

Gain error

AC-coupled.....	$\pm 2.0\%$ full scale range (FSR)
DC-coupled.....	$\pm 6.5\%$ full scale range (FSR)

³ Refer to Figures 8 and 9 for analog input return loss and VSWR.

⁴ Data is accessed using an I16 data type (left-justified).

⁵ For additional information about the ADC within your device, use the listed part number to locate the appropriate Texas Instruments data sheet at www.ti.com.

⁶ Available in the AC-coupled version and in TIS Enabled, Non-Multiplexed sampling mode only.

Table 6. Analog Input Jitter

Integration Range	Internal Free-Running	Internal Locked to IOModSyncCLK
10 Hz to 10 MHz	580 fs rms	770 fs rms
100 Hz to 10 MHz	95 fs rms	175 fs rms
10 kHz to 10 MHz	85 fs rms	85 fs rms

Table 7. Average Noise Density

	nV/ $\sqrt{\text{Hz}}$	dBm/Hz	dBFS/Hz
AC-coupled	30	-137.5	-147.5
DC-coupled	33	-136.6	-146.6

Table 8. AC Low Cut-Off Frequency (Referenced to Amplitude at 10 MHz)

	-3 dB	-1 dB
AC-coupled	110 kHz	240 kHz
DC-coupled	0 kHz	0 kHz

Table 9. Bandwidth And Spectral Performance Summary

Mode	Coupling	Bandwidth (-3 dB)	Bandwidth (-1 dB)	SNR (dB) ¹	SFDR (dBc) ¹	THD (dBc) ¹	ENOB (bits) ¹
TIS Disabled (default)	AC-coupled	2.27 GHz	780 MHz	58	-65	-63	9.2
	DC-coupled	358 MHz	320 MHz	57	-65	-64	9.1
TIS Enabled, Muxed to CH 0	AC-coupled	780 MHz	450 MHz	57	-63	-63	9.0
	DC-coupled	356 MHz	312 MHz	57	-63	-65	9.0
TIS Enabled, Muxed to CH 1	AC-coupled	780 MHz	450 MHz	57	-63	-63	9.0
	DC-coupled	356 MHz	312 MHz	57	-63	-65	9.0

Table 9. Bandwidth And Spectral Performance Summary (Continued)

Mode	Coupling	Bandwidth (-3 dB)	Bandwidth (-1 dB)	SNR (dB) ¹	SFDR (dBc) ¹	THD (dBc) ¹	ENOB (bits) ¹
TIS Enabled, Non-Muxed	AC-coupled	2.0 GHz	690 MHz	56	-60	-63	8.9
	DC-coupled	N/A	N/A	N/A	N/A	N/A	N/A

¹Measured using a -1 dBFS signal at 187 MHz.

Related Information

Analog Input Impedance on page 21

Analog Input Impedance

Analog Input Impedance

Figure 9. Analog Input Return Loss (Multiple Channels Overlaid)

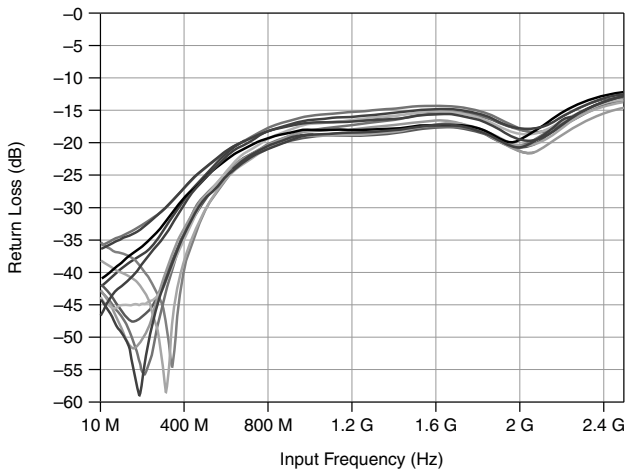
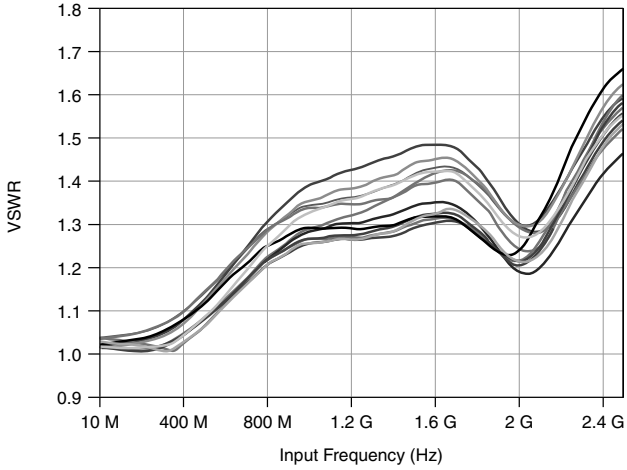

Figure 10. Analog Input VSWR (Multiple Channels Overlaid)



Frequency Response



Note Referenced at 10 MHz using +9 dBm.

Figure 11. AC Low Frequency Response (Referenced to Amplitude at 10 MHz)

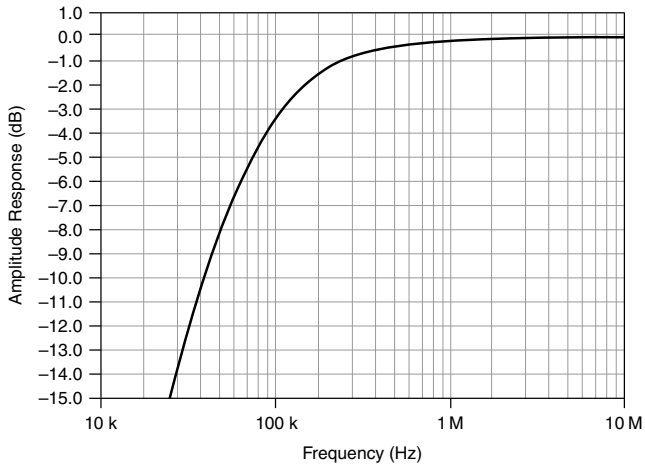

Figure 12. High Frequency Response (Referenced to Amplitude at 10 MHz)

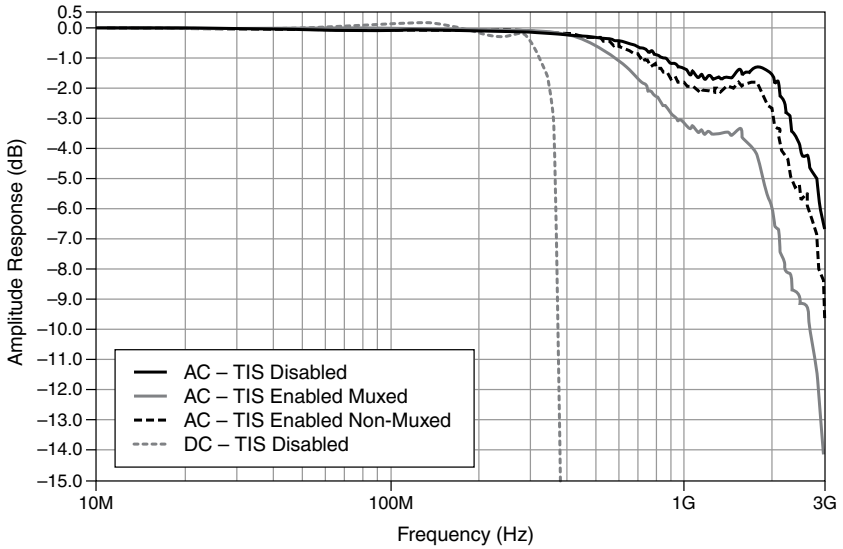

Figure 13. DC Bandwidth (Referenced to Amplitude at 10 MHz)

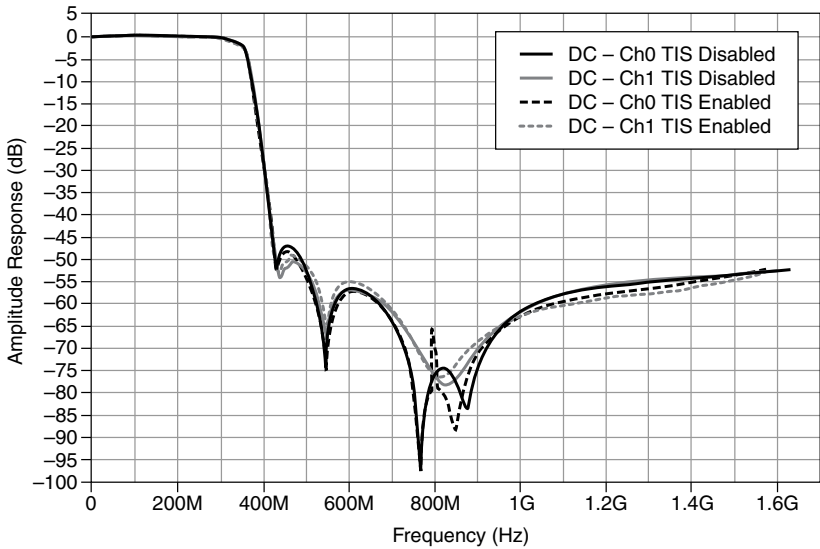
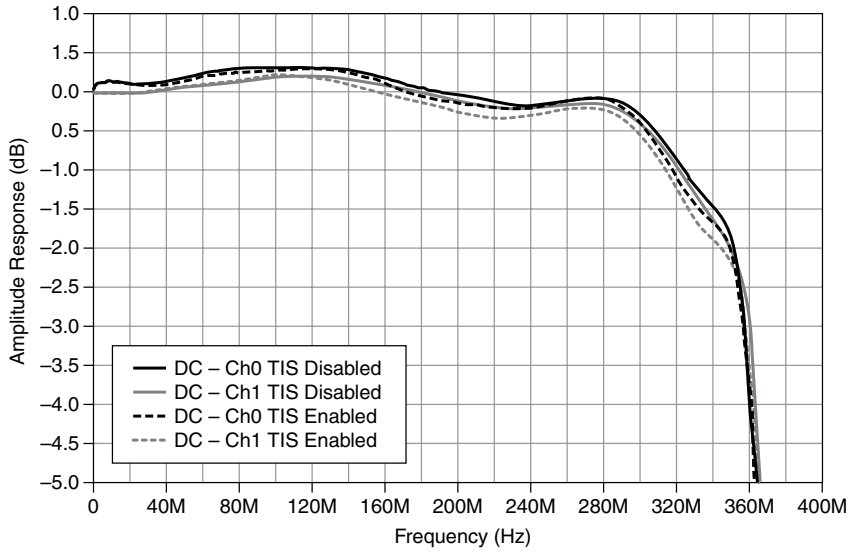

Figure 14. DC Bandwidth Flatness (Referenced to Amplitude at 10 MHz)



Spectral Measurements

Figure 15. Noise Density

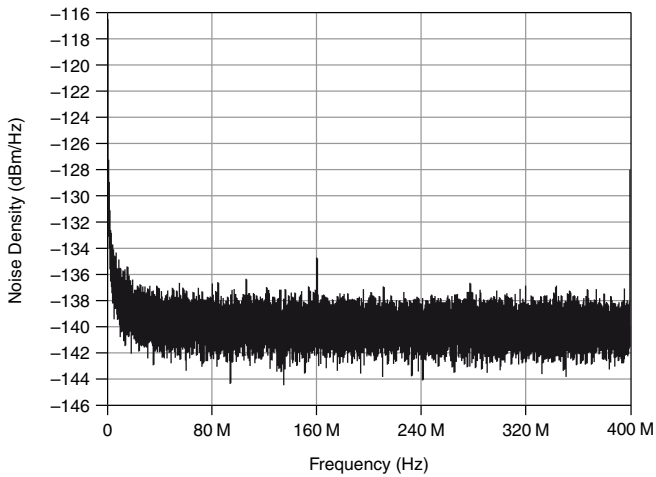

Figure 16. One-Tone Spectral Measurement (TIS Disabled, 187 MHz, -1 dBFS)

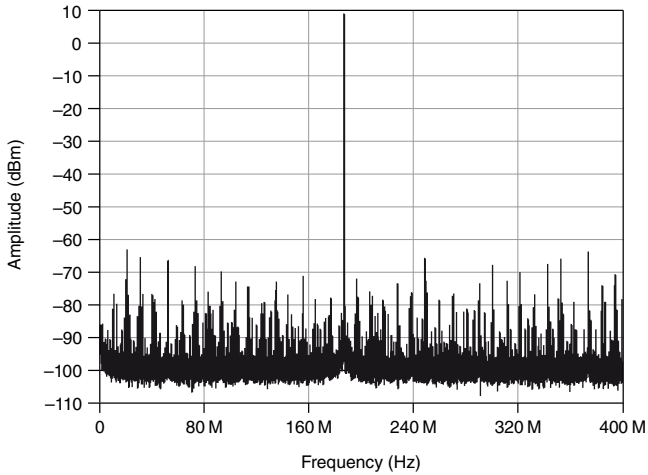
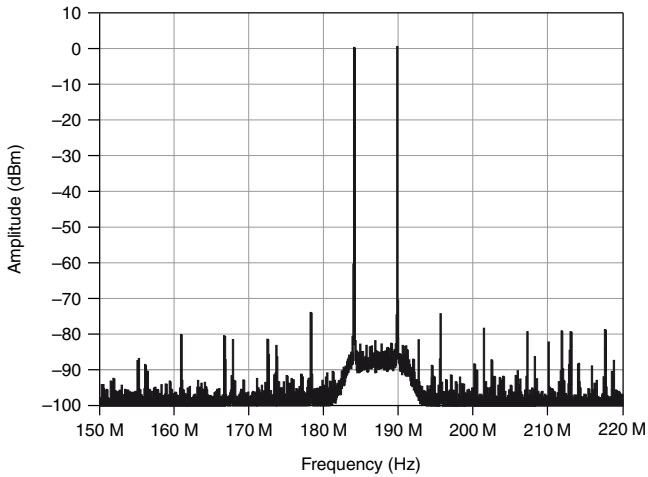
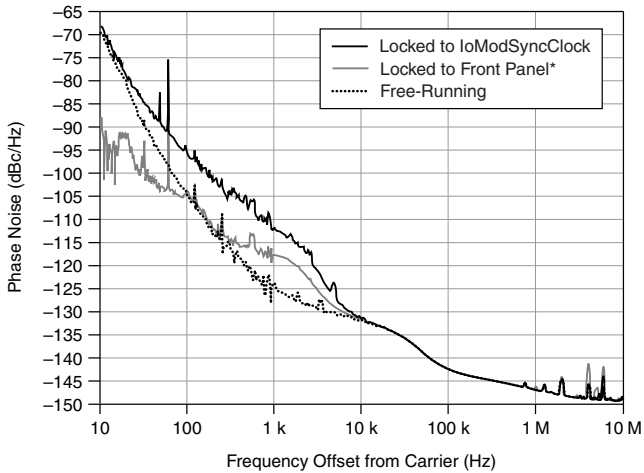

Figure 17. Two-Tone Spectral Measurement (TIS Multiplexed Mode, 182k Samples, 10 Averages)



Analog Input Total Phase Noise

Figure 18. Analog Input Total Phase Noise (353 MHz, -1 dBFS carrier)



*Uses a 10 MHz Wenzel OCXO (P/N: 501-04609A) as the reference signal.

Crosstalk

Figure 19. AI Crosstalk (Aggressor at -1 dBFS, Victim Terminated to 50 Ω)⁷

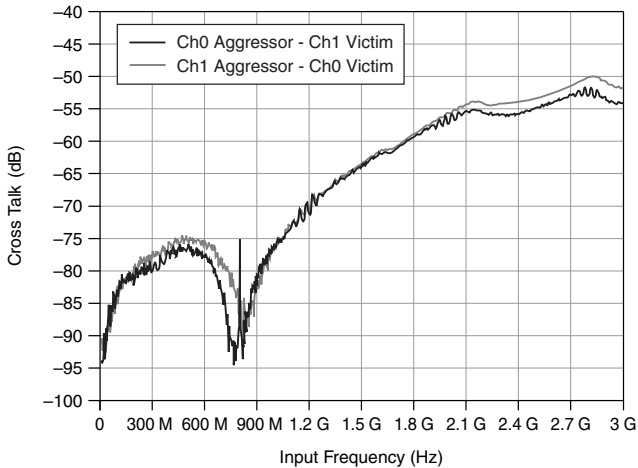

⁷ AC-coupled version only.

Figure 20. AI Crosstalk (Aggressor at -1 dBFS, Victim Terminated to 50 Ω)

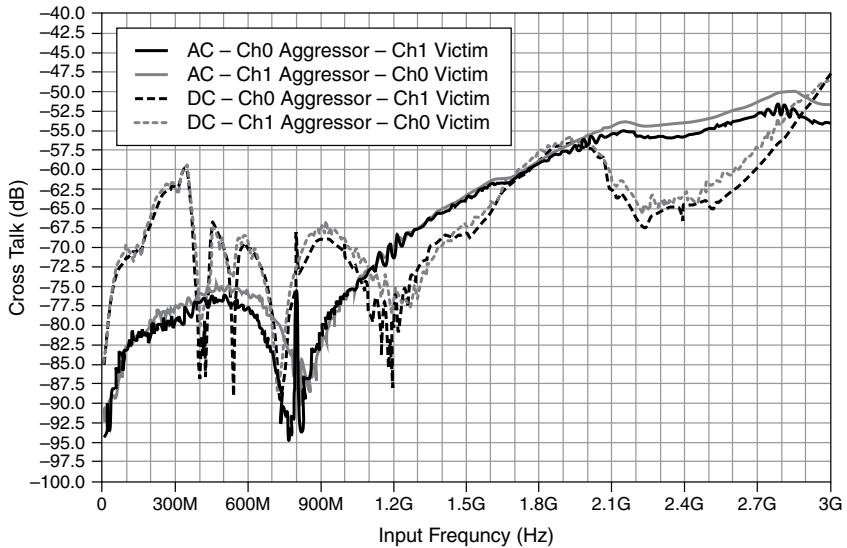

Related Information

[Typical Specifications](#) on page 19

Internal Sample Clock

General Characteristics

PLL part number.....	HMC703 ⁸
Oscillator type.....	VCO
Frequency.....	800 MHz \pm 25 ppm
Stability.....	\pm 5 ppm
Sampling jitter ⁹	90 fs rms

⁸ For additional information about the HMC703, refer to the Hittite data sheet at www.hittite.com.

⁹ Integrated from 100 Hz to 1,600 MHz.

CLK IN

General Characteristics

Number of channels.....	1, single-ended
Connector type.....	SMA
Frequency range.....	400 MHz to 800 MHz
Input impedance.....	50 Ω
Input coupling.....	AC
Input voltage range.....	+2 dBm (800 mV _{pk-pk}) to +16 dBm (4 V _{pk-pk})
Absolute maximum voltage.....	\pm 30 VDC, +21 dBm (7.1 V _{pk-pk})
Duty cycle.....	30% to 70%

REF IN

General Characteristics

Number of channels.....	1, single-ended
Connector type.....	SMA
Frequency.....	10 MHz
Input impedance.....	50 Ω
Input coupling.....	AC
Input voltage range.....	+2 dBm (800 mV _{pk-pk}) to 16 dBm (4 V _{pk-pk})
Absolute maximum voltage.....	\pm 30 VDC, +21 dBm (7.1 V _{pk-pk})
Duty cycle.....	30% to 70%

TRIG (I/O)

General Characteristics

Number of channels.....	1, single-ended
Connector type.....	SMA
Coupling.....	DC

Impedance

Input.....	20 k Ω
Output.....	50 Ω

Voltage

V _{IH}	2 V
V _{IL}	0.8 V
V _{OH}	2.3 V
V _{OL}	0.7 V

Absolute maximum voltage..... \pm 30 VDC, +21 dBm (7.1 V_{pk-pk})

AUX I/O (Port 0 DIO <0..3>, Port 1 DIO <0..3>, and PFI <0..3>)

Number of channels.....12 bidirectional (8 DIO and 4 PFI)

Connector type.....HDMI

Interface standard.....3.3 V LVCMOS

Interface logic

Maximum V _{IL}	0.8 V
Maximum V _{IH}	2.0 V
Maximum V _{OL}	0.4 V
Minimum V _{OH}	2.7 V
Maximum V _{OH}	3.6 V
Z _{out}	50 Ω \pm 20%
I _{out} (DC).....	\pm 2 mA

Pull-down resistor.....150 k Ω

Recommended operating voltage.....-0.3 V to 3.6 V

Overvoltage protection..... \pm 10 V

Maximum toggle frequency.....100 MHz

+5 V maximum power.....10 mA

+5 V voltage tolerance.....4 V to 5 V

EEPROM Map



Caution Only write to *User Space*. Writing to any other offset may cause the NI 5772 to stop functioning.

Table 10. EEPROM Map

Byte Address	Size (Bytes)	Field Name
0x0	2	Vendor ID
0x2	2	Product ID
0x4	4	Serial Number
0x8	116	Reserved
0x7C	132	User Space

Power

Total power, typical operation.....5.1 W

Physical

Dimensions.....12.9 x 2.0 x 12.1 cm (5.1 x 0.8 x 4.7 in.)

Weight.....660 g (23.3 oz)

Front panel connectors.....5 SMA connectors and one HDMI connector

Clean the hardware with a soft, nonmetallic brush. Make sure that the hardware is completely dry and free from contaminants before returning it to service.

Environment

Maximum altitude.....2,000 m (at 25 °C ambient temperature)

Pollution Degree.....2

Indoor use only.

Operating Environment

Ambient temperature range.....0 °C to 55 °C (Tested in accordance with IEC-60068-2-1 and IEC-60068-2-2.)

Relative humidity range.....10% to 90%, noncondensing



Note Using the NI 5772 in a manner not described in this document may impair the protection the NI 5772 provides.

(Tested in accordance with IEC-60068-2-56.)

Storage Environment

Ambient temperature range.....	-40 °C to 70 °C (Tested in accordance with IEC-60068-2-1 and IEC-60068-2-2.)
Relative humidity range.....	5% to 95%, noncondensing (Tested in accordance with IEC-60068-2-56.)
Operational shock.....	30 g peak, half-sine, 11 ms pulse (Tested in accordance with IEC-60068-2-27. Test profile developed in accordance with MIL-PRF-28800F.)
Random vibration	
Operating.....	5 Hz to 500 Hz, 0.3 g _{rms}
Nonoperating.....	5 Hz to 500 Hz, 2.4 g _{rms} (Tested in accordance with IEC-60068-2-64. Nonoperating test profile exceeds the requirements of MIL-PRF-28800F, Class 3.)

Compliance and Certifications

Safety

This product is designed to meet the requirements of the following electrical equipment safety standards for measurement, control, and laboratory use:

- IEC 61010-1, EN 61010-1
- UL 61010-1, CSA 61010-1



Note For UL and other safety certifications, refer to the product label or the [Online Product Certification](#) section.

Electromagnetic Compatibility

This product meets the requirements of the following EMC standards for electrical equipment for measurement, control, and laboratory use:

- EN 61326-1 (IEC 61326-1): Class A emissions; Basic immunity
- EN 55011 (CISPR 11): Group 1, Class A emissions
- AS/NZS CISPR 11: Group 1, Class A emissions
- FCC 47 CFR Part 15B: Class A emissions
- ICES-001: Class A emissions



Note In the United States (per FCC 47 CFR), Class A equipment is intended for use in commercial, light-industrial, and heavy-industrial locations. In Europe,

Canada, Australia, and New Zealand (per CISPR 11), Class A equipment is intended for use only in heavy-industrial locations.



Note Group 1 equipment (per CISPR 11) is any industrial, scientific, or medical equipment that does not intentionally generate radio frequency energy for the treatment of material or inspection/analysis purposes.



Note For EMC declarations, certifications, and additional information, refer to the *Online Product Certification* section.

CE Compliance

This product meets the essential requirements of applicable European Directives, as follows:

- 2006/95/EC; Low-Voltage Directive (safety)
- 2004/108/EC; Electromagnetic Compatibility Directive (EMC)

Online Product Certification

To obtain product certifications and the DoC for this product, visit ni.com/certification, search by model number or product line, and click the appropriate link in the Certification column.

Environmental Management

NI is committed to designing and manufacturing products in an environmentally responsible manner. NI recognizes that eliminating certain hazardous substances from our products is beneficial not only to the environment but also to NI customers.

For additional environmental information, refer to the *Minimize Our Environmental Impact* web page at ni.com/environment. This page contains the environmental regulations and directives with which NI complies, as well as other environmental information not included in this document.

Waste Electrical and Electronic Equipment (WEEE)



EU Customers At the end of the product life cycle, all products must be sent to a WEEE recycling center. For more information about WEEE recycling centers, National Instruments WEEE initiatives, and compliance with WEEE Directive 2002/96/EC on Waste Electrical and Electronic Equipment, visit ni.com/environment/weee.

电子信息产品污染控制管理办法（中国 RoHS）



中国客户 National Instruments 符合中国电子信息产品中限制使用某些有害物质指令 (RoHS)。关于 National Instruments 中国 RoHS 合规性信息，请登录 ni.com/environment/rohs_china。(For information about China RoHS compliance, go to ni.com/environment/rohs_china.)

Worldwide Support and Services

The National Instruments website is your complete resource for technical support. At ni.com/support you have access to everything from troubleshooting and application development self-help resources to email and phone assistance from NI Application Engineers.

Visit ni.com/services for NI Factory Installation Services, repairs, extended warranty, and other services.

Visit ni.com/register to register your National Instruments product. Product registration facilitates technical support and ensures that you receive important information updates from NI.

A Declaration of Conformity (DoC) is our claim of compliance with the Council of the European Communities using the manufacturer's declaration of conformity. This system affords the user protection for electromagnetic compatibility (EMC) and product safety. You can obtain the DoC for your product by visiting ni.com/certification. If your product supports calibration, you can obtain the calibration certificate for your product at ni.com/calibration.

National Instruments corporate headquarters is located at 11500 North Mopac Expressway, Austin, Texas, 78759-3504. National Instruments also has offices located around the world. For telephone support in the United States, create your service request at ni.com/support or dial 512 795 8248. For telephone support outside the United States, visit the *Worldwide Offices* section of ni.com/niglobal to access the branch office websites, which provide up-to-date contact information, support phone numbers, email addresses, and current events.

Installing PXI EMC Filler Panels

To ensure specified EMC performance, PXI EMC filler panels must be properly installed in your NI FlexRIO system. The PXI EMC filler panels (National Instruments part number 778700-01) must be purchased separately. For more installation information, refer to the *NI FlexRIO FPGA Module Installation Guide and Specifications*.

1. Remove the captive screw covers.
2. Install the PXI EMC filler panels by securing the captive mounting screws to the chassis, as shown in the figure below. Make sure that the EMC gasket is on the right side of the PXI EMC filler panel.

Figure 21. PXI EMC Filler Panels and Chassis

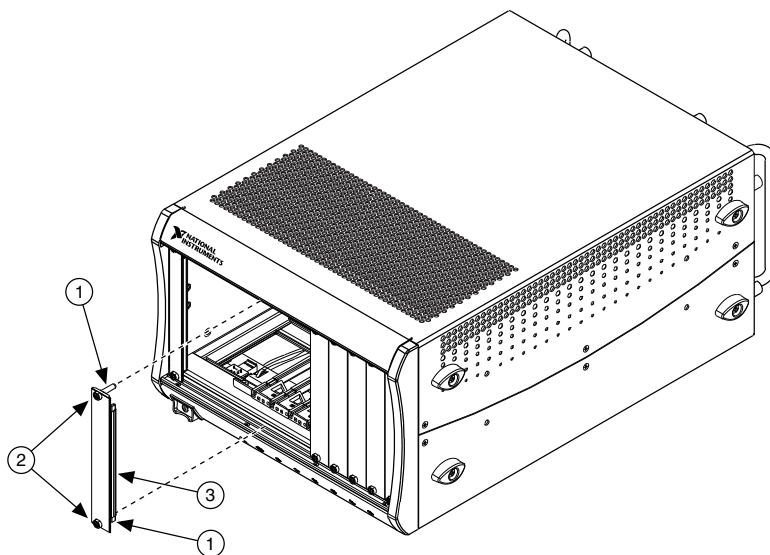

1. Captive Screw Covers
2. Captive Mounting Screws
3. EMC Gasket



Note You must populate all slots with a module or a PXI EMC filler panel to ensure proper module cooling. Do not over tighten screws (2.5 lb · in maximum). For additional information about the use of PXI EMC filler panels in your PXI system, visit ni.com/info and enter `emcpanels`.

Related Information

[Electromagnetic Compatibility Guidelines](#) on page 2

Refer to the *NI Trademarks and Logo Guidelines* at ni.com/trademarks for information on National Instruments trademarks. Other product and company names mentioned herein are trademarks or trade names of their respective companies. For patents covering National Instruments products/technology, refer to the appropriate location: **Help»Patents** in your software, the `patents.txt` file on your media, or the *National Instruments Patent Notice* at ni.com/patents. You can find information about end-user license agreements (EULAs) and third-party legal notices in the readme file for your NI product. Refer to the *Export Compliance Information* at ni.com/legal/export-compliance for the National Instruments global trade compliance policy and how to obtain relevant HTS codes, ECCNs, and other import/export data.

© 2012–2013 National Instruments. All rights reserved.

373625B-01 Jul13